

Automated and efficient for the future

Bosch Mobility Solutions

Steering systems for commercial vehicles



Power-on-demand

Automated driving

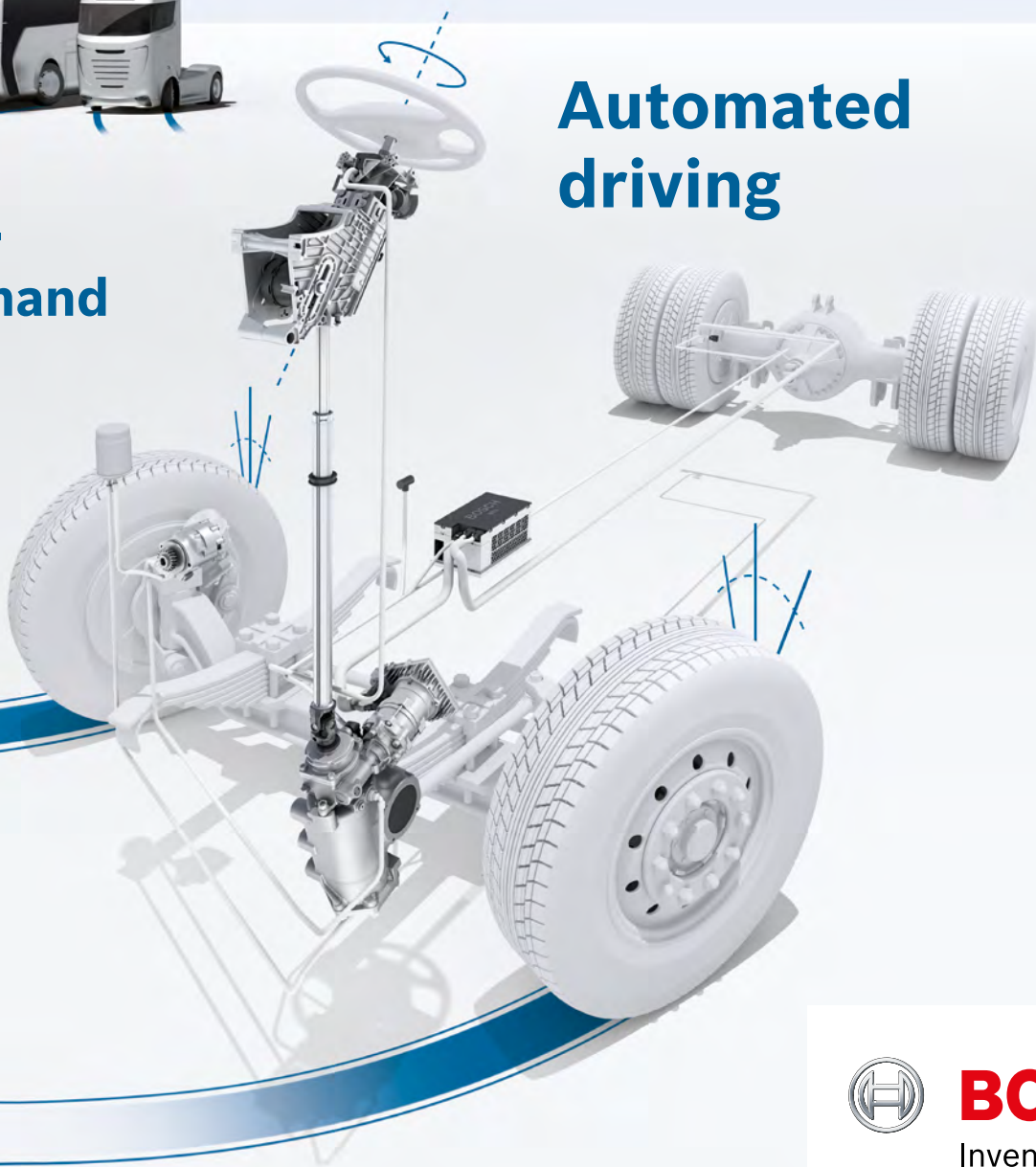

BOSCH
Invented for life

Steer into the future – with Bosch steering systems

COMPREHENSIVE RANGE FOR THE IDEAL STEERING FEEL

Rapidly growing challenges in the transport and logistics sector demand technical solutions, which increase efficiency and safety as well as making sure that drivers can work ergonomically and comfortably on long hauls. As a supplier of individual components and complete steering systems for medium-duty and heavy-duty commercial vehicles, Robert Bosch Automotive Steering stands for excellent vehicle handling and optimum steering assistance. Our comprehensive range, which includes all the principal components between the steering wheel and the wheels (wheel-to-wheel), meets all the requirements of our customers.

STRENGTH OF INNOVATION PLUS KNOW-HOW

As the market leader worldwide, Robert Bosch Automotive Steering offers ball-and-nut power steering systems that are proven millions of times over. Our electrohydraulic steering system is the innovative combination of a ball-and-nut power steering and an electric drive and electronic control unit. This means that, by taking other parameters such as speed and load into account, the steering feel can be optimized to its maximum. RB-Servoline®, a linear steering system with rack-and-pinion, is particularly well suited to heavy-duty commercial vehicles with independent suspension. The range from Robert Bosch Automotive Steering also includes low-consumption power steering pumps, continuously adjustable steering columns, robust connecting shafts between steering gears and steering column, and low-wear bevel boxes.

ACHIEVE MORE WITH LESS

Our innovative products contribute in many ways to the increased efficiency of commercial vehicles. The benefits extend from low energy requirement (power-on-demand principle), through to weight savings and optimized design, and as far as reductions in the number of components required.

ASSISTANCE SYSTEMS AND AUTOMATED DRIVING

The linking of the vehicle's electrohydraulic steering system and on-board network enables new driver assistance functions. Functions like side wind compensation, lane-keeping, hands-on-wheel detection and traffic jam assist can be integrated into the vehicle and help to increase safety and relieve the strain on drivers effectively. Thanks to the many linking features available, intelligent steering systems from Robert Bosch Automotive Steering are a key technology in implementing automated driving functions in commercial vehicles.

Roadmap

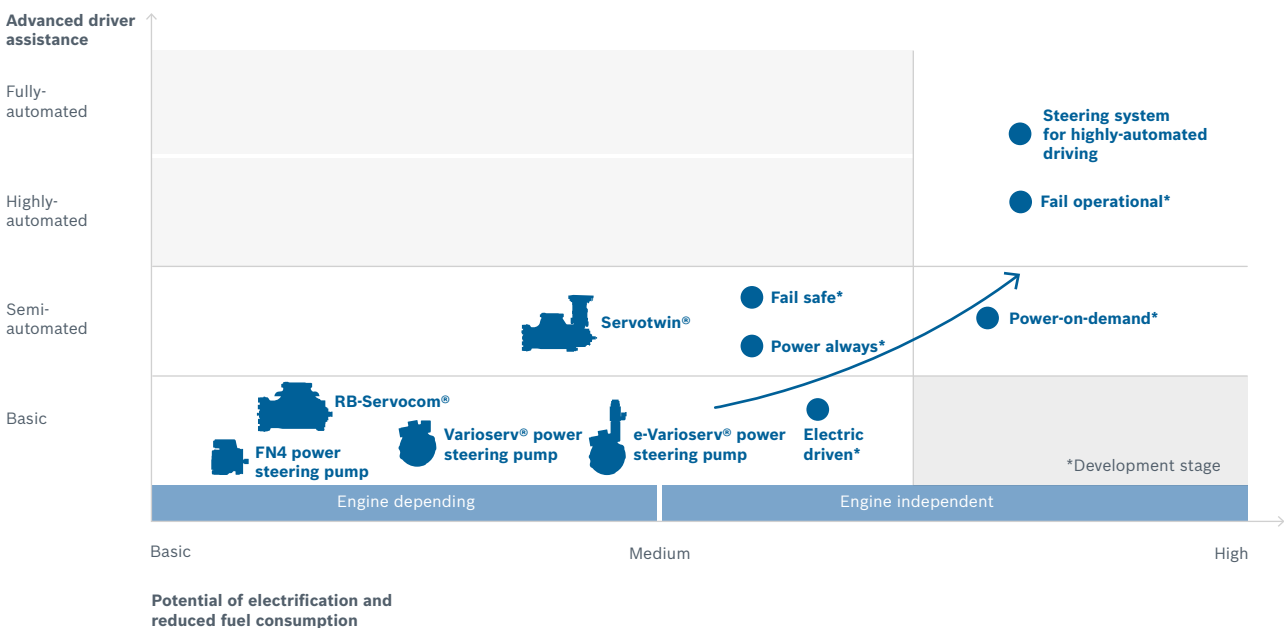

active safety

Steering systems from Robert Bosch Automotive Steering make it possible to have driver assistance systems and partly-automated driving in commercial vehicles.

-1,600 g

When compared with conventional dual-circuit steering systems, Servotwin® reduces the CO₂ emissions of commercial vehicles by an average of 1,600 g/100 km.

-0.6 l

When compared with conventional dual-circuit steering systems, Servotwin® reduces the fuel consumption of commercial vehicles by an average of 0.6l/100km.

Power-on-demand

The rear axle steering system only consumes energy, when steering is actually taking place. When driving in a straight line, the energy consumption is virtually zero.

-0.6 l

The rear axle steering system reduces fuel consumption by an average of 0.6l/100 km (depending on the usage profile).

SYSTEM BENEFITS

- ▶ Assistance functions and partly-automated driving are possible through the linking of the steering to the on-board network
- ▶ Increases safety, efficiency and comfort
- ▶ Saves fuel and CO₂ emissions
- ▶ Speed-dependent assistance for steering
- ▶ Maintenance-free

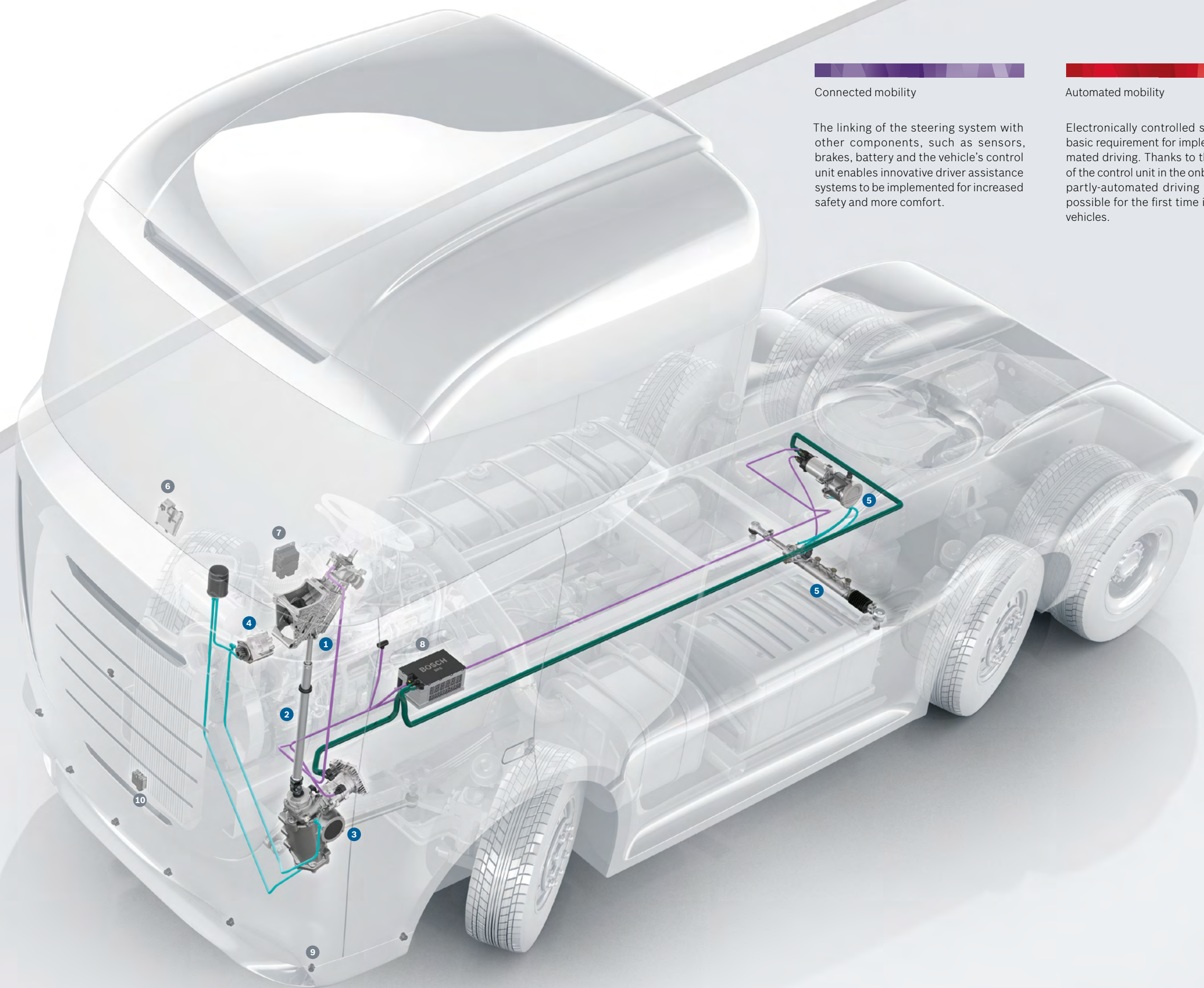

Connected mobility

The linking of the steering system with other components, such as sensors, brakes, battery and the vehicle's control unit enables innovative driver assistance systems to be implemented for increased safety and more comfort.

Automated mobility

Electronically controlled steering is the basic requirement for implementing automated driving. Thanks to the integration of the control unit in the onboard network, partly-automated driving functions are possible for the first time in commercial vehicles.

Powertrain systems and electrified mobility

Electrically assisted and electronically controlled steering systems are a key technology for the electrification of the drivetrain. They enable fuel consumption and CO₂ emissions to be reduced significantly.

System components

- 1 Steering column
- 2 Steering shaft
- 3 Electrohydraulic steering system
- 4 Power steering pump
- 5 Rear axle steering system

Other components

- 6 Multi purpose camera
- 7 Central control unit for driver assistance functions
- 8 On-board network
- 9 Ultrasonic sensors
- 10 Radar

Steering systems

Servotwin®



BOSCH

Invented for life

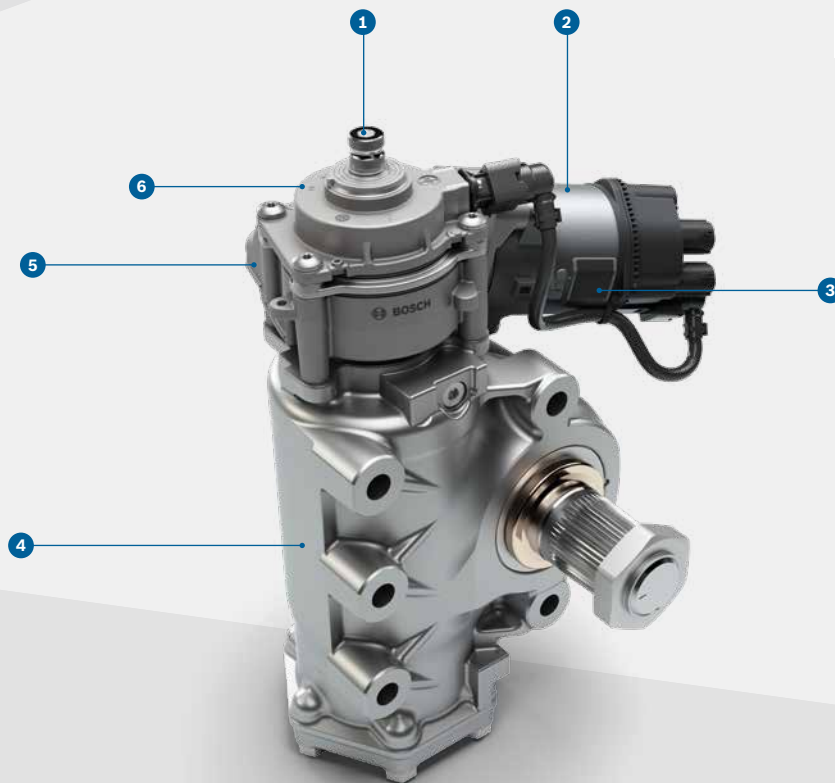

PRODUCT BENEFITS

- ▶ Enables semi-automated driving
- ▶ Relieves stress on the driver
- ▶ Fuel savings
- ▶ Active steering return
- ▶ Speed-dependent steering assistance
- ▶ High damping of pavement effects
- ▶ Modular lightweight electric servounit

- 1 Steering spindle connection
- 2 Electric motor
- 3 Control unit
- 4 RB-Servocom®
- 5 Worm gear
- 6 Sensor unit



reduced driver exertion

Thanks to lower steering forces when maneuvering and parking in conjunction with active steering return, driver exertion is reduced noticeably.

TASK

The Servotwin® electrohydraulic steering system for heavy commercial vehicles is the result of the innovative combination of the RB-Servocom® recirculating ball-gear power steering system with an electronic control unit. The system offers speed-based steering assistance with active return as well as a variety of driver assistance functions. The electrical circuit replaces the previously needed second hydraulic circuit for commercial vehicles with two steered axles.

FUNCTION

Servotwin® consists essentially of two components: the timetested RB-Servocom® ball-gear power steering system and a platform-based combination of an electric motor with control unit and worm gear. The ball-gear power steering system provides most of the steering assistance. Its design is based on the principle employed in a classic hydraulic power steering system. Here, an oil circuit and a power cylinder provide the hydraulic steering assistance for the steering wheel motions of the driver. Using an electric motor and worm gear, an additional turning moment can be applied to the input shaft of the RB-Servocom® in parallel to the steering wheel's moment. In this way, the manual force needed for steering can be varied depending on the driving situation. The mechanical connection from the steering wheel to the steering linkage is preserved. A turning motion of the steering wheel and the applied steering moment are sensed by turning angle and torque sensors and transmitted to the electronic control unit (ECU). By taking other vehicle parameters into account – for instance, speed and load – the ECU determines the required additional steering moment and actuates the electric motor. On the basis of

semi-automated driving

for greater safety and more convenience

–0.6 l/100 km

compared to conventional dual-circuit steering systems (depending on application profile)

the specific driving situation, the electric motor assists the steering motion by adding or subtracting a steering moment and in this way electronically optimizes the process of steering. The steering feel can thus be optimized for the driver at any time through the additional, electrically generated steering moment. To protect the steering system against overload when the wheels are turned to the full-lock position, an electronic stop can be freely programmed. In addition to comfort functions and driver assistance functions (e.g. side wind compensation, lane keeping function, traffic jam assist) Servotwin also enables automated driving functions in heavy commercial vehicles by connecting the steering system with the on-board electronics.

TECHNICAL CHARACTERISTICS

Model size	8298
Steering axle load	5,500 – 8,500 kg
Hydraulic torque ($\eta = 0.9$)	7,050 – 8,294 Nm
Electric torque	65 Nm
Max. oil pressure	185 bar
Max. oil delivery rate	25 dm ³ /min
Dry weight	49 kg

- 1 Piston
- 2 Sector shaft
- 3 Housing
- 4 Steering spindle connection
- 5 Worm
- 6 Ball chain

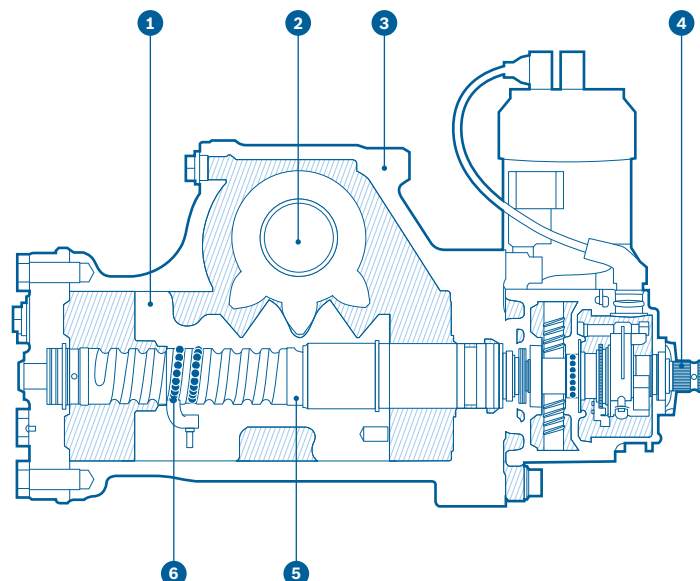

Steering systems

RB-Servocom®



BOSCH

Invented for life

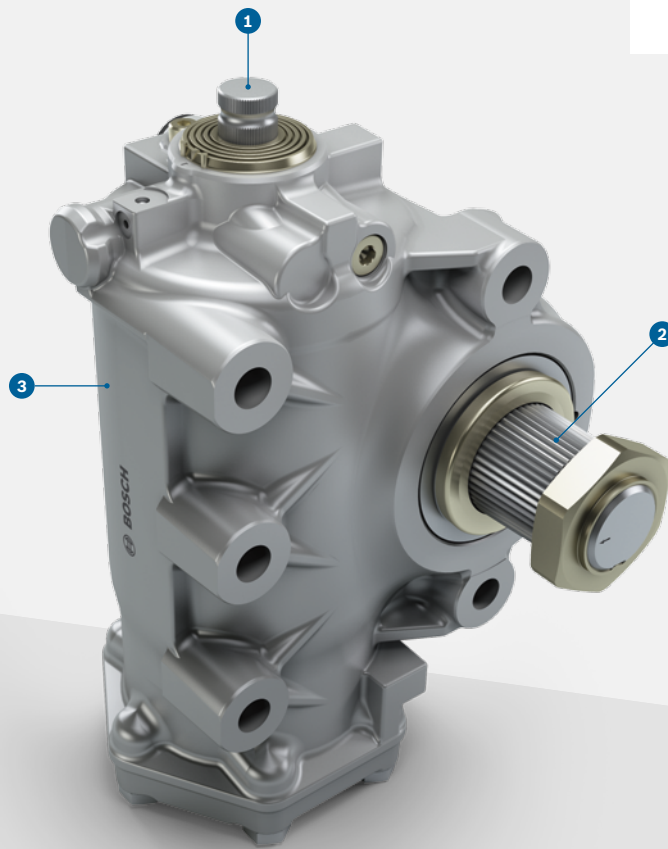

PRODUCT BENEFITS

- ▶ Optimal steering feel and precision
- ▶ Light weight
- ▶ Compact design packaging
- ▶ High performance
- ▶ High stiffness
- ▶ Low energy consumption
- ▶ Low wear and maintenance-free

- 1 Steering spindle connection
- 2 Sector shaft
- 3 Housing



high reliability

through its rugged design – proven 11 million times in all markets and applications

TASK

The RB-Servocom® hydraulic steering system is the compact solution for heavy commercial vehicles. The recirculating ball gear hydraulic steering principle has been developed continuously in the RB-Servocom® and as a result satisfies a wide variety of customer requirements.

FUNCTION

The essential characteristics of the RB-Servocom® are a rugged cast iron housing with integrated, mechanical steering gear assembly, control valve and power cylinder.

A turning motion of the steering wheel is transmitted to the worm gear by the steering spindle connection and converted into an axial motion of the piston by means of a recirculating ball thread. At the same time, the sector shaft, which is perpendicular to the axis of the piston, is put into rotational motion by a gear arrangement. The drop arm attached to the sector shaft moves the steering linkage connected to the control arms, causing the wheels to turn. The oil from the steering pump flows through the supply channels to the control grooves of the rotary valve, and when the valve is in the neutral position, it flows back into the return line and oil reservoir over the open control edges. When the steering wheel is turned, the rotary valve rotates with respect to the control sleeve. This directs the oil flow into the cylinder chamber that assists the rotating motion, where it acts on the piston surface in the power cylinder and provides the desired hydraulic assistance to the axial motion of the piston. To protect the steering linkage, wheel stops, and steering pump, the RB-Servocom® is equipped with integrated hydraulic steering limiter. Just before the piston reaches its end position, the steering limit valve opens and reduces the

- 1 Piston
- 2 Sector shaft
- 3 Housing
- 4 Steering spindle connection
- 5 Worm
- 6 Ball chain

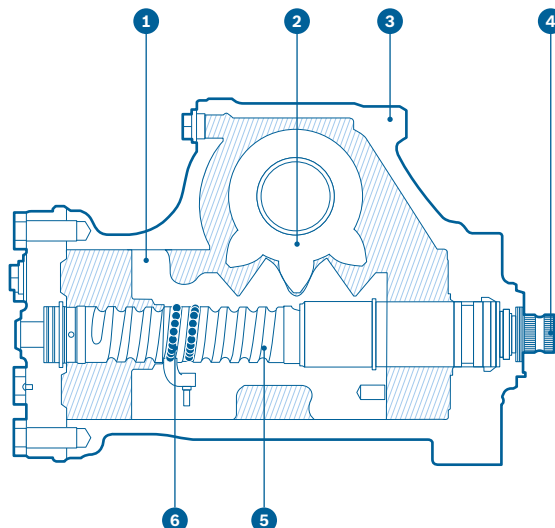

best power-to-weight ratio

of all hydraulic block steering systems

high steering precision

The RB-Servocom® hydraulic steering system provides excellent handling and thus safe, sensitive steering of heavy commercial vehicles.

hydraulic assistance substantially. Various special versions of the RB-Servocom® are available to meet a wide variety of customer requirements, for instance, dual-circuit designs or versions with an attached bevel box assembly.

TECHNICAL CHARACTERISTICS

Model size	8090	8095	8097	8098
Front axle load	<4.2*	<6.5*	<7.3*	>6.0*
Transmission ratio	i-variable 14.0–16.6	i-variable 15.7–18.5	i-variable 17.4–20.4	i-variable 22.2–26.2 15.2–17.9
Pressure (bar)	190+10	170+15	185+15	185+15
Max. output torque [Nm ($\eta=0.9$)]				
at $\alpha=0^\circ$	2,589	4,375	5,751	7,049
at $\alpha=47^\circ$	3,059	5,148	6,794	8,294
Weight (kg)	17	28	36	43

* Values depend on various axle parameters.

Steering systems

Rear axle steering system



BOSCH

Invented for life

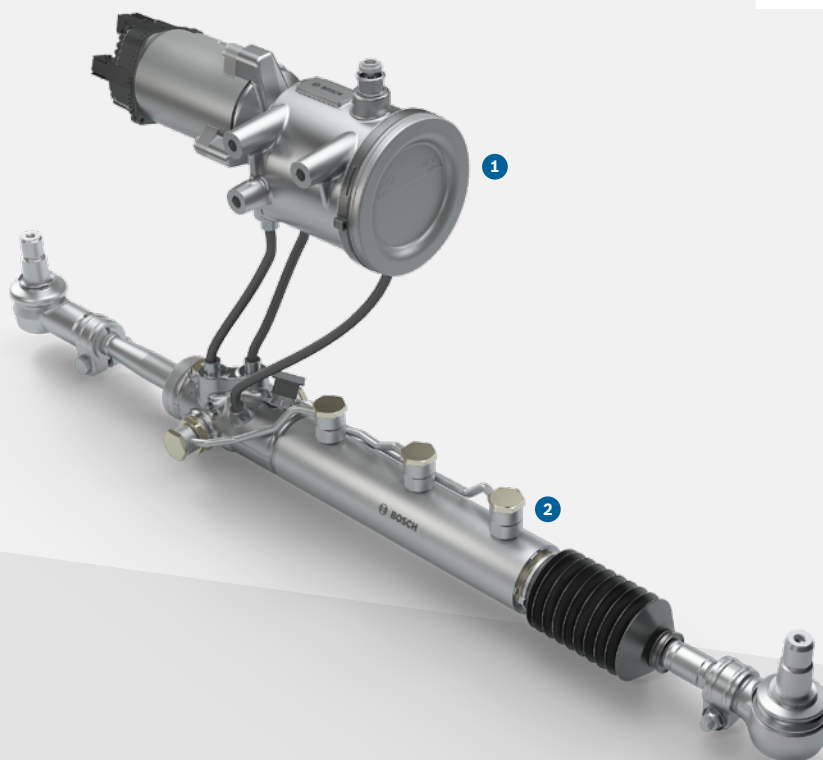

PRODUCT BENEFITS

- ▶ Smaller turning circle
- ▶ Reduced tire wear
- ▶ Compact construction
- ▶ Light weight
- ▶ Fuel savings
- ▶ Increased maneuverability
- ▶ Easy installation

- 1 Power unit with integrated control unit
- 2 Steering cylinder with integrated position sensor



Power-on-demand

The electrohydraulic rear axle steering system only uses energy when steering is actually occurring.

TASK

The electrohydraulic rear axle steering system is a stand-alone power-on-demand system for steering the pusher axle or the tag axle of heavy commercial vehicles. It is the result of an innovative combination of a hydraulic cylinder unit and an electronic power unit. The system makes it possible to steer pusher and trailing axles on vehicles with three or more axles.

FUNCTION

The rear axle steering system consists essentially of two components: the cylinder unit with integrated position sensor and valve system, and the power unit, consisting of a motor-driven pump and control unit. The ever more demanding requirements faced by commercial vehicles in today's transportation industry can only be satisfied on the rear axle through use of an innovative steering system with electronic interface. With the system, the linking of the rear axle steering to the vehicle's electrical system is now possible. The available vehicle signals (e.g. steering angle of the front axle) on the CAN bus are transmitted to the integrated control unit (ECU). From these signals, the rear axle steering system determines the desired steering angle of the rear axle and controls the pump by means of the electric motor on the basis of the target-actual comparison. The volume-flow generated acts on the particular piston surface of the cylinder unit and moves the cylinder's piston rod in or out, until the integrated position sensor gives the return signal, that the target position has been reached. The wheels on

21 W

are required, on average, for operation of the rear axle steering system.

-0.6 l/100 km

lower fuel consumption – compared to conventional electrohydraulic rear axle steering systems

the axle are turned to the desired angle by coupling the cylinder unit to a control arm, which transmits the steering forces via the tie rods. With its freely programmable and plug-and-play capability, the independent and compact construction makes it possible to steer several axles on a vehicle through use of several rear axle steering systems.

To protect the steering system against overloading when the wheels are turned to the full-lock position, an electronic stop can be programmed. The control unit then decreases the flow from the pump as soon as the programmed end stop is reached so that the mechanical stops are not damaged.

TECHNICAL CHARACTERISTICS

Piston rod force	41/52 kN (retract/extend)
Max. pressure	185 bar
Installed length	1,000 mm +/- 95 mm
Operating temperature	-32 °C to +80 °C
Surface treatment	DIN EN ISO 9227 - 480 h
Operating voltage	24 V DC
Weight	24 kg

- 1 Electric motor with ECU
- 2 Oil tank with pump
- 3 Steering cylinder with integrated position sensor
- 4 Valve system

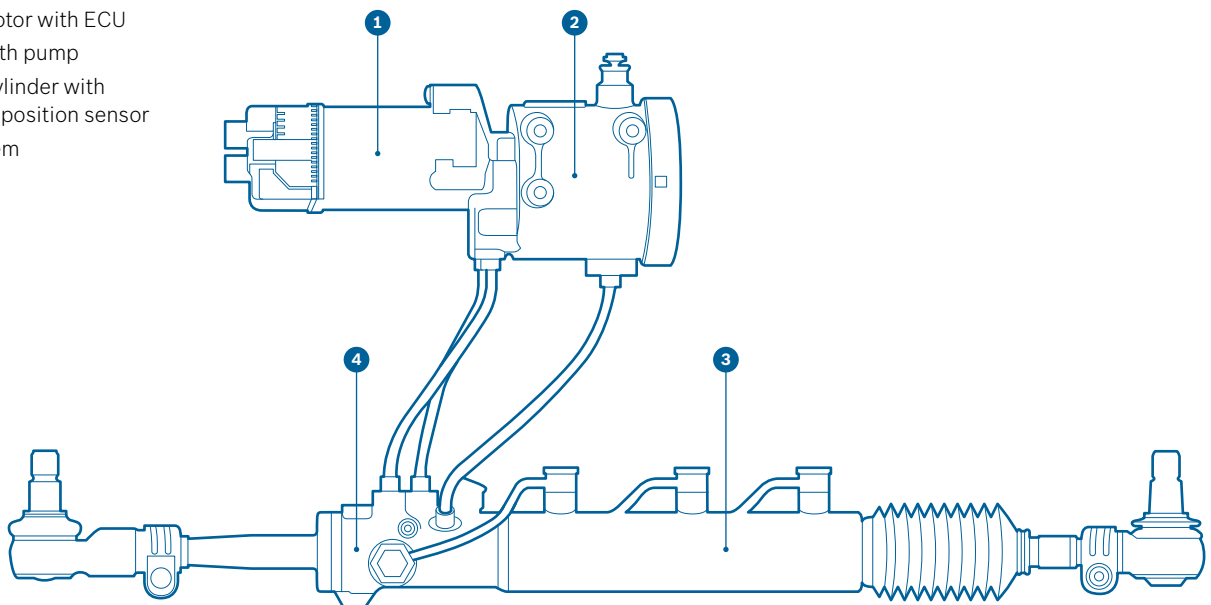

Steering systems

Electrohydraulic power steering pump (EHPS)



BOSCH

Invented for life

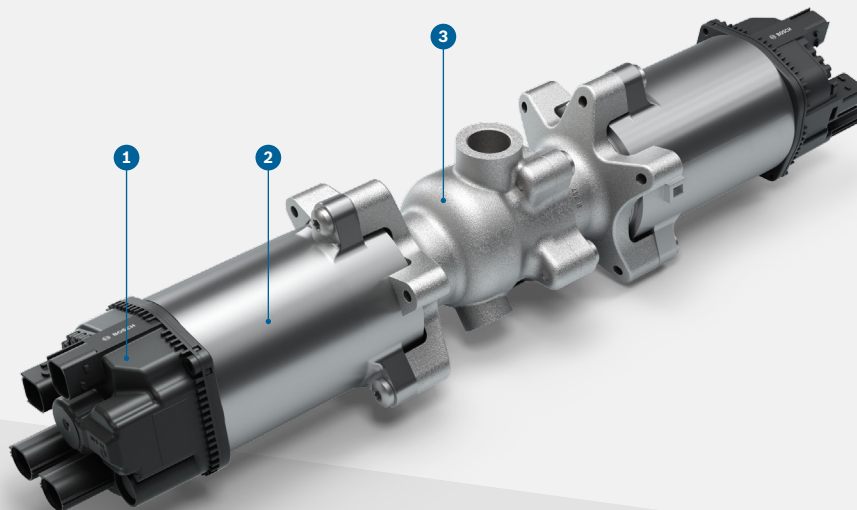

PRODUCT BENEFITS

- ▶ Full functionality independent of internal combustion engine
- ▶ Fail-operational functionality due to redundant power pack
- ▶ Significantly reduced power consumption due to power on demand
- ▶ No need for high voltage protection (24 volts)
- ▶ Reduced system temperature

- 1 Power electronics with ports for energy and data
- 2 Electric motor
- 3 Pump with suction port and pressure port



up to
70 %

energy saving compared to conventional power steering pump with constant displacement volume

TASK

The electrohydraulic power steering pump provides the demand-oriented amount of oil and pressure that is needed to operate the hydraulic steering systems of commercial vehicles at any given time.

FUNCTION

The EHPS consists of two electric motors, each equipped with an electronic control unit, a vane pump and an optional customer-specific mounting bracket. The integrated power electronics controls the speed of the motors synchronously in accordance with the requirements of the steering maneuver (setpoint setting). The motors rotate in opposite directions here. The motors are permanently excited brushless direct current motors (BLDC motors) – consisting of a housing, a stator and a rotor. The vane pump is driven simultaneously by both motors via a common shaft. The speed of the motors and pump is identical. The volumetric oil flow generated by the pump is directly proportional to the speed and displacement volume of the pump. The vane pump essentially consists of the housing, cover, front plate, shaft and rotor set. The rotor set consists of the rotor, radially directed vanes in the rotor and the cam ring. The pump is designed as a dual-circuit pump.

VARIANTS

The electrohydraulic power steering pump EHPS with two power packs is designed for use in medium-duty and heavy-duty commercial vehicles and busses. An EHPS with just one power pack may be suitable for use in light commercial vehicles.

Power on demand

Energy intake varies according to the driving situation

TECHNICAL CHARACTERISTICS

Displacement volume [l/min]	4 to 18
Max. pressure [bar]	185
Suction port thread	1 1/16" – 12UN 2B M26 × 1,5
Pressure port thread	3/4" – 16UNF 2B M18 × 1,5
Operating temperature [°C]	-40 to +100
Rated current (max. current consumption) [A]	150 (184)
Rated voltage (voltage range) [V]	24 (16 to 32)
Electrical rated output (max. power consumption) [W]	1800 (2200)
E-motor type	2 × BLDC
Power electronics	integrated
Sensors for positioning (per motor)	1 × AMR 1 × hall sensor
Communication	CAN bus
Weight [kg]	11.5

- 1 Suction port
- 2 Housing
- 3 Rotor with vanes
- 4 Shaft
- 5 Cam ring
- 6 Pressure connection

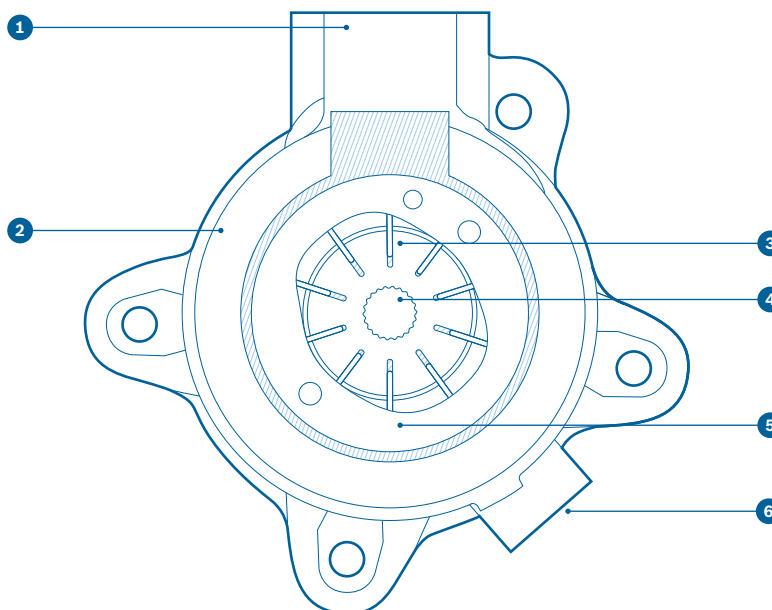

Steering systems

e-Varioserv® power steering pump



BOSCH

Invented for life

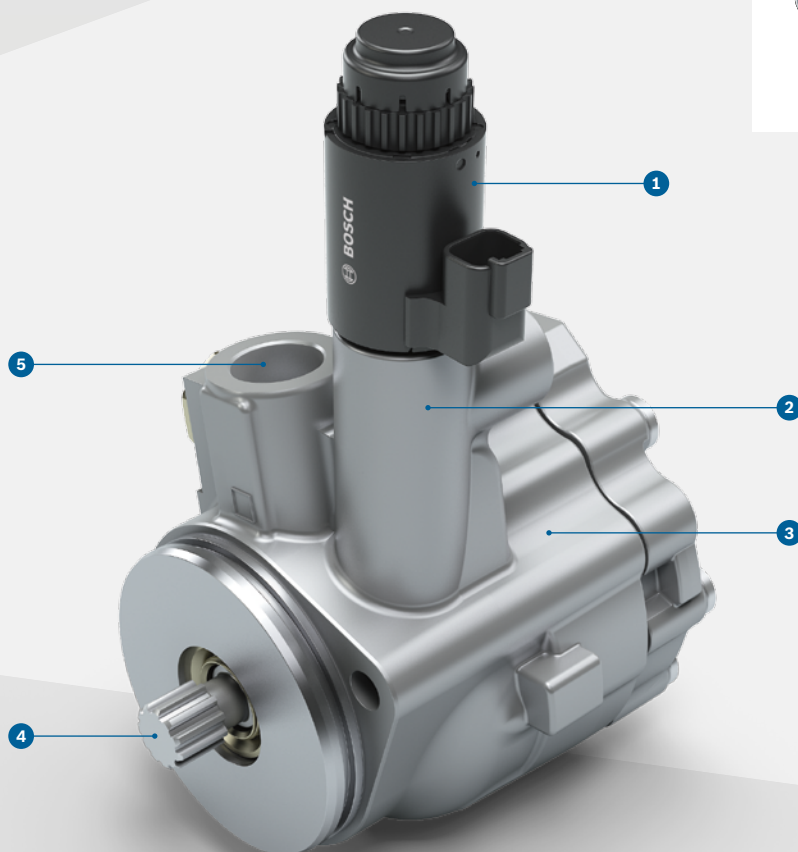

PRODUCT BENEFITS

- ▶ Demand-based volumetric flow control
- ▶ Power consumption reduced even further than that of the Varioserv® power steering pump
- ▶ Lower operating temperature in the steering system
- ▶ Reduced fuel consumption compared to a conventional as well as a Varioserv® power steering pump
- ▶ Lower CO₂ emissions
- ▶ The same flange pattern as conventional and Varioserv® power steering pumps

- 1 Electronically controlled orifice (ECO)
- 2 Pressure port
- 3 Housing with integrated flange
- 4 Driveshaft
- 5 Suction port

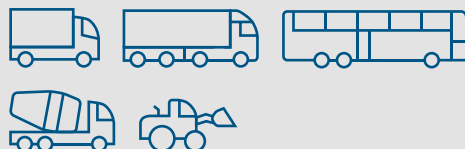

up to
15 °C

lower temperature in the steering system, which means less cooling required and improved system efficiency

TASK

The e-Varioserv® power steering pump provides the amount of oil needed at any time for operation of hydraulic steering systems in commercial vehicles. The pump is designed primarily for connection to the air compressor or a power take-off on an engine. The shaft connects by means of a cross-slotted disk or splines.

FUNCTION

The e-Varioserv® power steering pump consists essentially of the housing with integrated control valve, cover, front plate, shaft, rotor set, and an ECO (electronically controlled orifice). Depending on the vehicle-specific requirements, the ECO permits a further demand-based reduction of the volumetric flow compared to that of a Varioserv® pump.

The rotor set consists of the rotor, eleven radial vanes installed in the rotor, the cam ring and the outer ring. The cam ring in the e-Varioserv® is positioned eccentrically and hydraulically adjustable. Until a fixed control point is reached, the e-Varioserv® operates like a conventional power steering pump. Once this control point is reached, the geometric delivery volume is decreased by repositioning the cam ring to provide the defined flow. The ECO provides a further reduction of the specified flow. Control of the ECO is based on vehicle-specific requirements. The lower flow compared to that of a Varioserv® power steering pump translates into reduced power consumption and, in turn, a lower system temperature.

VARIANTS

Gear or pulley drive. A pressure of up to 200 bar is available if necessary. The e-Varioserv® can be combined in tandem with other pump types (e.g. fuel pre-supply pumps).

TECHNICAL CHARACTERISTICS

Model	7654	7655	7656	7657
Theor. displacement volume (cm ³ /rev)	22	25	28	34
Max. rotational speed (rpm)	5,000	5,000	5,000	5,000
Max. pressure (bar)	185	185	185	185
Controlled volumetric flow (l/min)	5/25	5/25	5/25	5/25
Suction port thread	1 1/16" – 12UN 2B M26 × 1.5			
Pressure port thread	3/4" – 16UNF 2B M18 × 1.5			
Drive direction of rotation	clockwise or counterclockwise			

up to
65 %

lower fuel consumption and CO₂ emissions compared to a conventional power steering pump (depending on vehicle type, up to 0.3l/100km or 7.8g CO₂/100km)

- 1 Electronically controlled orifice (ECO)
- 2 Pressure port
- 3 Housing
- 4 Driveshaft
- 5 Outer ring
- 6 Cam ring
- 7 Suction port

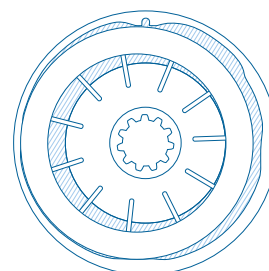
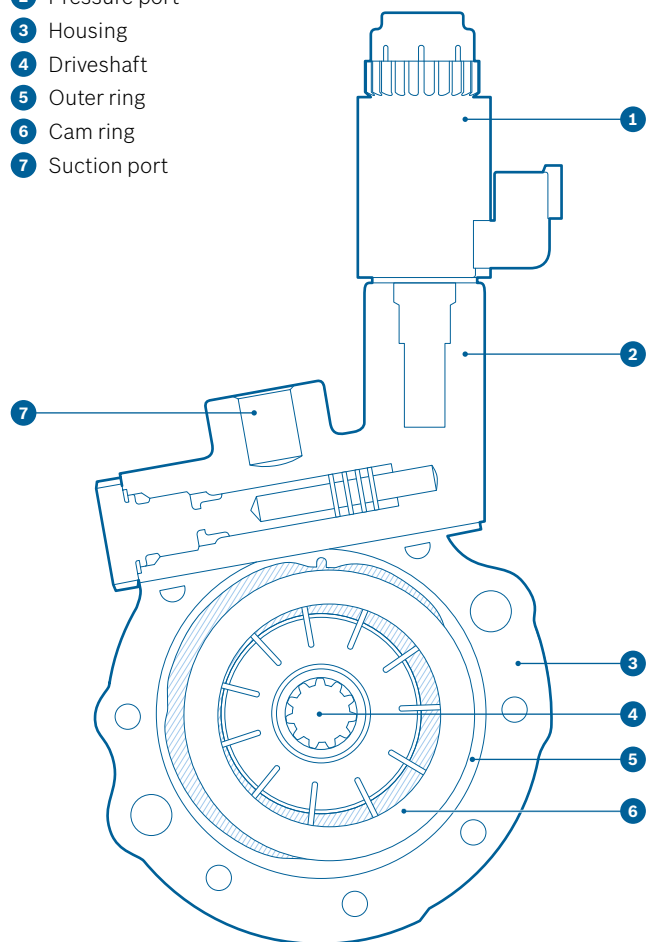

Eccentric bearing of cam ring for maximum delivery capacity

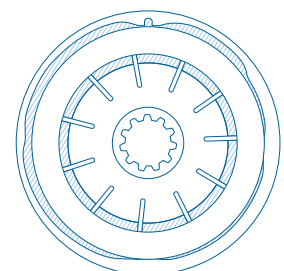

Concentric bearing of cam ring for minimum delivery capacity

Steering systems

Varioserv® power steering pump



BOSCH

Invented for life

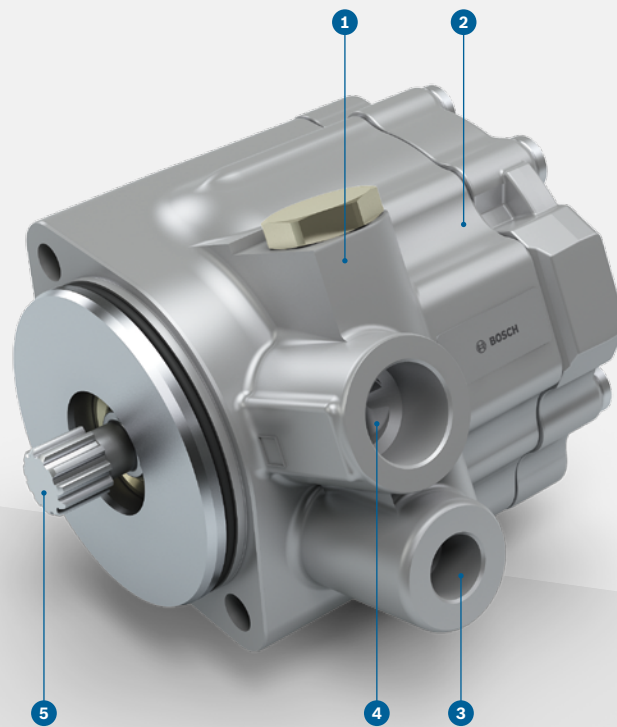

PRODUCT BENEFITS

- ▶ Reduced power consumption compared to a conventional power steering pump
- ▶ Reduced fuel consumption compared to a conventional power steering pump and lower CO₂ emissions
- ▶ Lower operating temperature in the steering system
- ▶ Same flange pattern as a conventional power steering pump
- ▶ Tandem-capable power steering pump

- 1 Control valve
- 2 Housing with integrated flange
- 3 Pressure port
- 4 Suction port
- 5 Driveshaft



up to
15 °C

lower temperature in the steering system, which means less cooling required and improved system efficiency

TASK

The Varioserv® power steering pump provides the amount of oil needed at any time for operation of hydraulic steering systems in commercial vehicles. The pump is designed primarily for connection to the air compressor or a power take-off on an engine. The shaft connects by means of a cross-slotted disk or splines.

FUNCTION

The Varioserv® power steering pump consists essentially of the housing with integrated control valve, cover, front plate, shaft and rotor set. The rotor set consists of the rotor, eleven radial vanes installed in the rotor, the cam ring and the outer ring. The cam ring in the Varioserv® is positioned eccentrically and hydraulically adjustable. Until a fixed control point is reached, the Varioserv® operates like a conventional power steering pump. Once this control point is reached, the geometric delivery volume is decreased by repositioning the cam ring to provide the defined flow. The fixed flow is controlled on the basis of the engine rpm and pressure requirement. The lower flow compared to that of a conventional power steering pump translates into reduced power consumption and, in turn, a lower system temperature. The maximum system pressure must be limited by a pressure-limiting valve installed on the pump or in the system.

VARIANTS

Gear or pulley drive. A pressure of up to 200 bar is available if necessary. The Varioserv® can be combined in tandem with other pump types (e.g. fuel pre-supply pumps).

TECHNICAL CHARACTERISTICS

Model	7654	7655	7656	7657
Theor. displacement volume (cm ³ /rev)	22	25	28	34
Max. rotational speed (rpm)	5,000	5,000	5,000	5,000
Max. pressure (bar)	185	185	185	185
Controlled volumetric flow (l/min)	16/25	16/25	16/25	16/25
Suction port thread	1 1/16" – 12UN 2B M26 × 1.5			
Pressure port thread	3/4" – 16UNF 2B M18 × 1.5			
Drive direction of rotation	clockwise or counterclockwise			

up to
40 %

lower fuel consumption and CO₂ emissions compared to a conventional power steering pump (depending on vehicle type, up to 0.2l/100km or 5.2g CO₂/100km)

- 1 Control valve
- 2 Suction port
- 3 Pressure port
- 4 Housing
- 5 Driveshaft
- 6 Outer ring
- 7 Cam ring

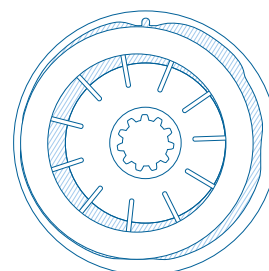
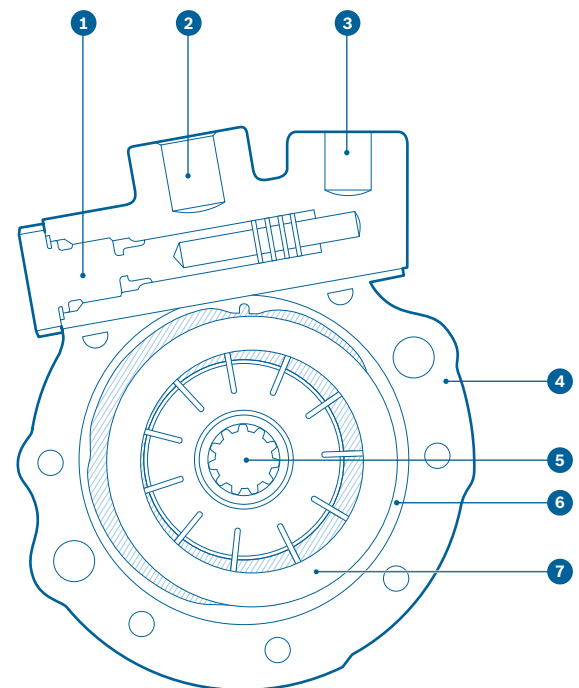

Eccentric bearing of cam ring for maximum delivery capacity

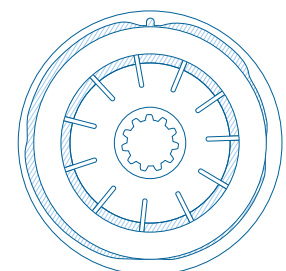

Concentric bearing of cam ring for minimum delivery capacity

Steering systems

Power steering pump FN4



BOSCH

Invented for life

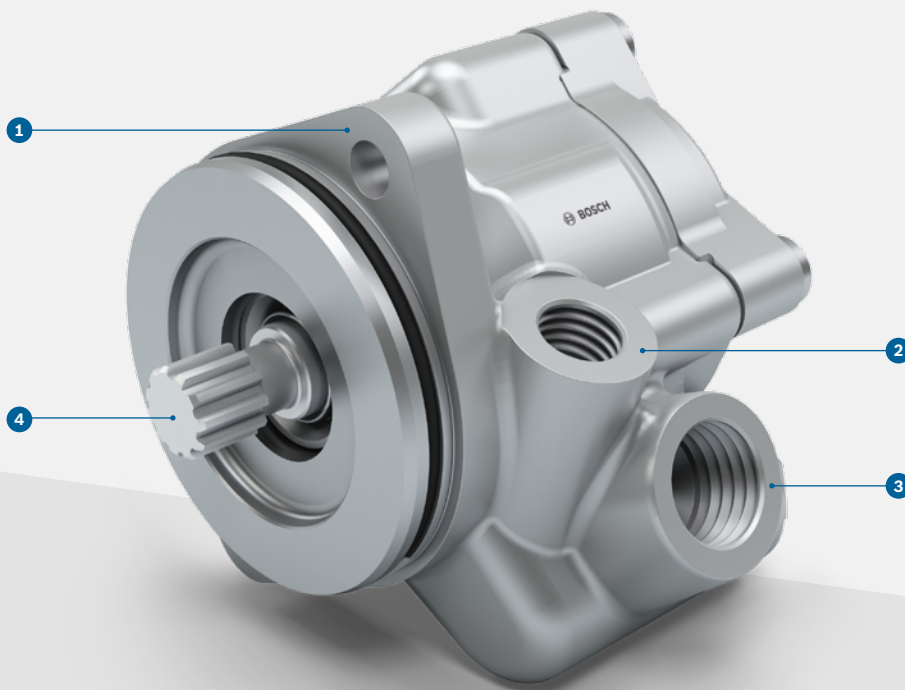

PRODUCT BENEFITS

- ▶ Compact construction
- ▶ High efficiency with low weight
- ▶ High component flexibility through modular system concept
- ▶ Integrated volume flow control
- ▶ Optionally with integrated pressure limiting

- 1 Casing with integrated flange
- 2 Pressure connection
- 3 Suction connection
- 4 Shaft

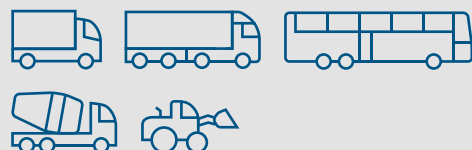

rugged design

The proven design ensures a reliable supply of oil to the steering system.

TASK

The power steering pump FN4 provides the amount of oil needed for operation of hydraulic steering systems in commercial vehicles at all times. The pump is designed primarily for connection to the compressed-air compressor or the power take-off on an engine. The shaft connects by means of a cross-slotted disk or splines. The pump can be driven by either a gear or belt. For these cases, an anti-friction bearing is used for the driveshaft. The ball bearing needed for the above instances can be incorporated into the housing. In addition, an oil reservoir can be mounted directly to the pump. This eliminates the hose and assembly costs at the vehicle manufacturer.

FUNCTION

The power steering pump FN4 consists essentially of housing with integrated volume flow control, cover, faceplate, shaft and rotor set. The rotor set consists of the rotor, ten radial vanes installed in the rotor, and the cam ring. The cam ring has two symmetrically positioned suction and pressure zones. The design of the cam ring defines the fixed geometric delivery volume of the pump. The integrated volume flow control limits the volumetric flow delivered to a fixed value. The maximum system pressure must be limited by a pressure-limiting valve installed on the pump or in the system. If required by the steering system design, a pressure level of up to 200 bar is available as a special version.

high power density

with low weight

TECHNICAL CHARACTERISTICS

Model	7683	7684	7685	7686	7687
Delivery volume (cm ³ /U)	14	17	21	25	28
Max. rotational speed (rpm)	4,500	4,500	4,000	4,000	3,500
Max. pressure (bar)	185	185	185	185	165
Controlled volumetric flow (l/min)	9–16	12–16	12–25	16–25	16–25
Suction connection Thread	1 1/16" – 12UN 2B M26 × 1.5				
Pressure connection Thread	3/4" – 16UNF 2B M18 × 1.5				
Max. oil temperature (°C)	120				
Weight (kg)	2.3–2.8				
Drive direction of rotation	clockwise or counterclockwise				

- 1 Casing with integrated flange
- 2 Shaft
- 3 Pressure connection
- 4 Suction connection

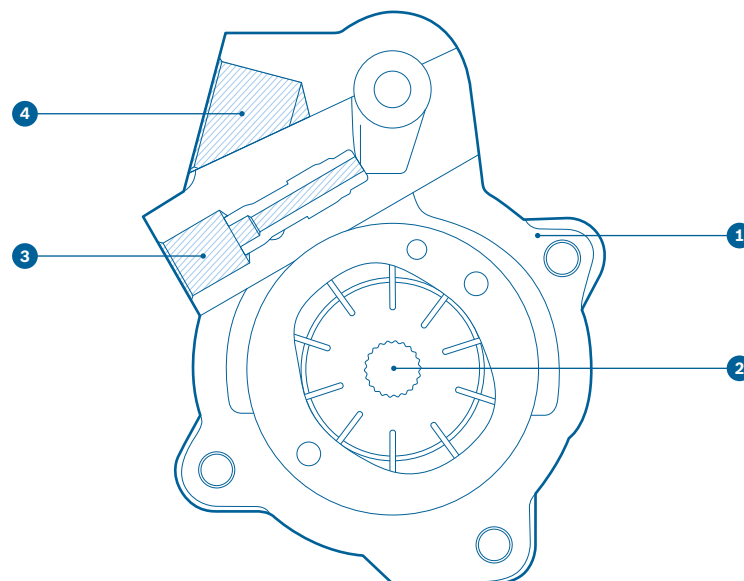

Steering systems

Steering column



BOSCH

Invented for life

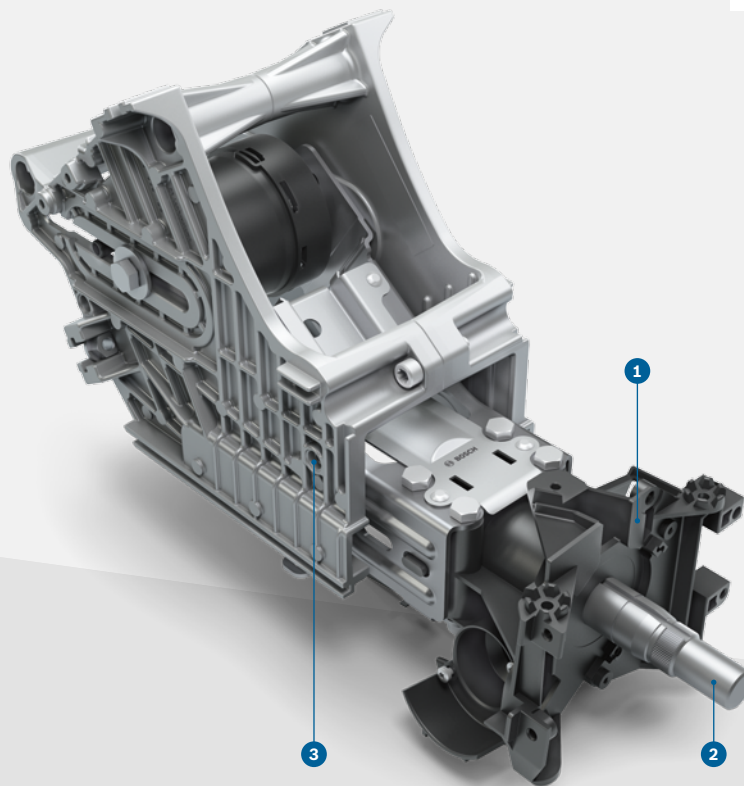

PRODUCT BENEFITS

- ▶ High transversal stiffness
- ▶ Low turning torque
- ▶ Minimal displacement forces
- ▶ High clamping force
- ▶ Minimal rotational nonuniformity through optimal placement of universal joints and pivot points
- ▶ Integration of clamping device, steering column switch, contact unit, and steering angle sensor

- 1 Upper steering spindle housing
- 2 Steering wheel connection
- 3 Support, including fastening means



continuously adjustable

For an ergonomic driving position, the steering column is continuously adjustable in terms of height and angle.

TASK

Steering columns hold the steering wheel, switches, etc. and provide the connection between the steering wheel, the steering shaft, and the steering gear. They are used on medium and heavy commercial vehicles and buses. The steering column, which provides continuously adjustable positioning of the steering wheel in terms of height and angle, offers particular benefits along with additional convenience functions.

FUNCTION

A modular system ensures maximum variability. The support is manufactured from a lightweight alloy or steel as required by the individual application. A gas spring or cylindrical compression spring integrated into the ball-joint shaft balances the weight distribution between the steering unit and the steering wheel, steering column, switch and, possibly, instrument panel during the adjustment procedure. It is also possible to place the gas spring between the support and board wall.

TECHNICAL CHARACTERISTICS*

Operating temperature	-40 °C to +80 °C
Turning torque	<0.3 Nm
Displacement force	Extension: ≤200 N Retraction: ≤60 N
Min. pressure for clamping cylinder	7.8 bar
Height adjustment	82 mm
Weight	6.1 kg
Swivel angle	21° (10°/11°)
Center position to vertical	30°
Stalling torque	≤10 Nm

*Depends on customer specifications; enhanced specifications possible depending on customer requirements

lower weight

through use of lightweight components made of magnesium and plastic

- 1 Adjustable steering column
- 2 Steering shaft
- 3 RB-Servocom® steering gear
- 4 Bevel box

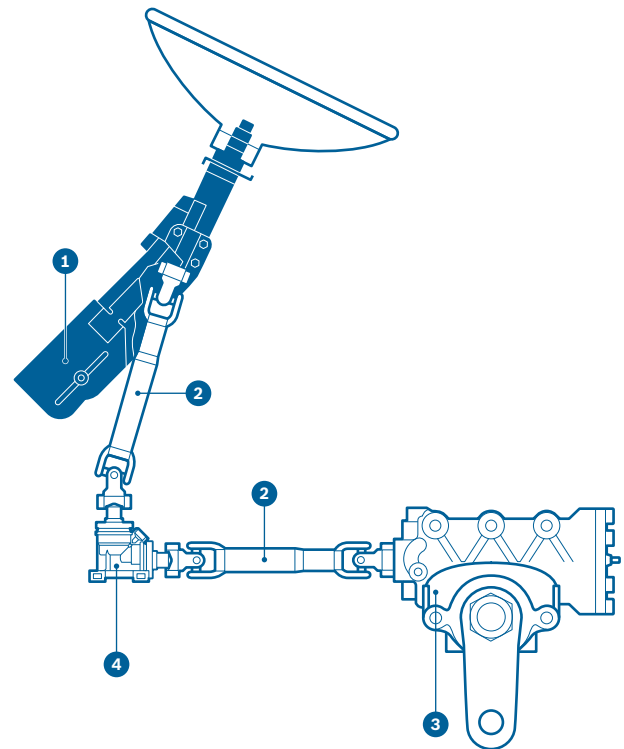

Steering systems

Steering shaft



BOSCH

Invented for life

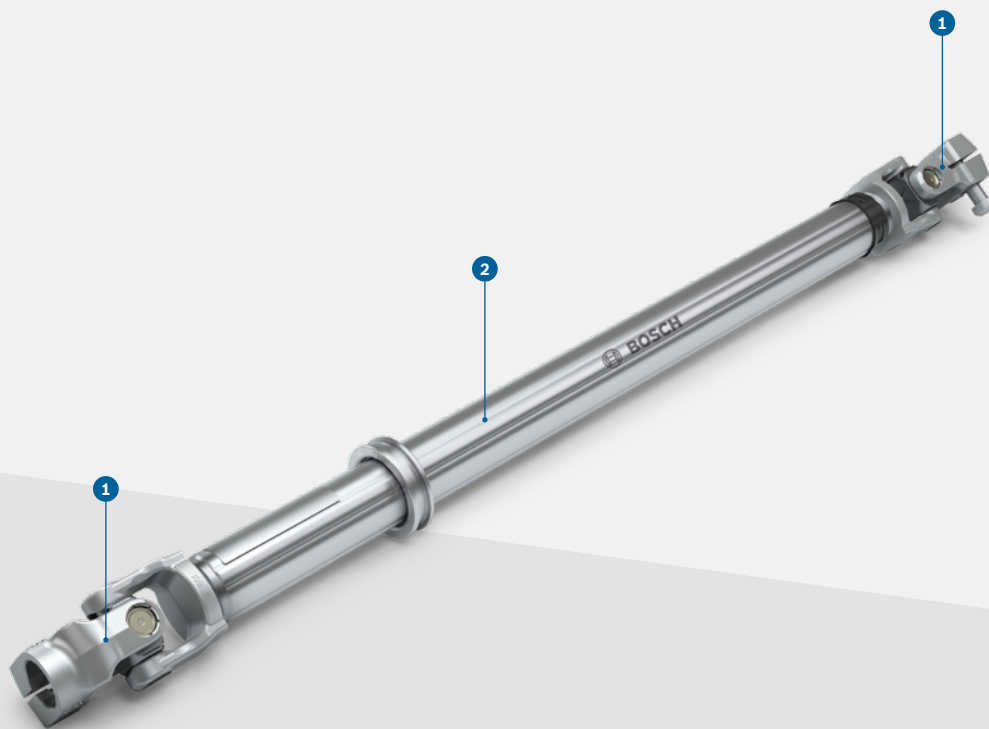

PRODUCT BENEFITS

- ▶ Precision ball guide
- ▶ High torsional stiffness
- ▶ Compact universal joints
- ▶ Low displacement forces
- ▶ Galvanic corrosion protection, Cr VI-free
- ▶ Modular system

1 Universal joint

2 Outer tube



35°

maximum bending angle for comfortable and safe steering

TASK

Steering shafts are the connection between the steering gear and steering column, and are used on medium and heavy commercial vehicles and buses. The ball-guide principle used is continuously undergoing further development to meet the requirements of our customers for minimal play and maximum service life.

FUNCTION

The major components of the Bosch steering shaft are an outer tube with ball-guide grooves inside and a profiled shaft with outer ball-guide grooves. Two axially positioned rows of balls provide a noise-free connection. This design guarantees zero-play radially, but easy axial repositioning with a usable travel of ± 28 mm. The overall length of the low-wear and maintenance-free component can be matched to vehicle requirements. Incorporation of a cylindrical compression spring further provides a comfortable weight compensation in conjunction with an adjustable steering column.

VARIANTS

The steering shaft is available in different tube lengths and angular joint positions.

up to
1.2 kg

lower weight than conventional steering shafts

TECHNICAL CHARACTERISTICS

Installed length	min. 281 mm (retracted) max. 3,915 mm (extended)
Bending angle	max. 35°
Enveloping circle diameter	tube 38.6 mm joint 66 mm
Displacement force	max. rolling friction 20 N max. sliding friction 60 N

- 1 Adjustable steering column
- 2 Steering shaft
- 3 RB-Servocom® steering gear
- 4 Bevel box

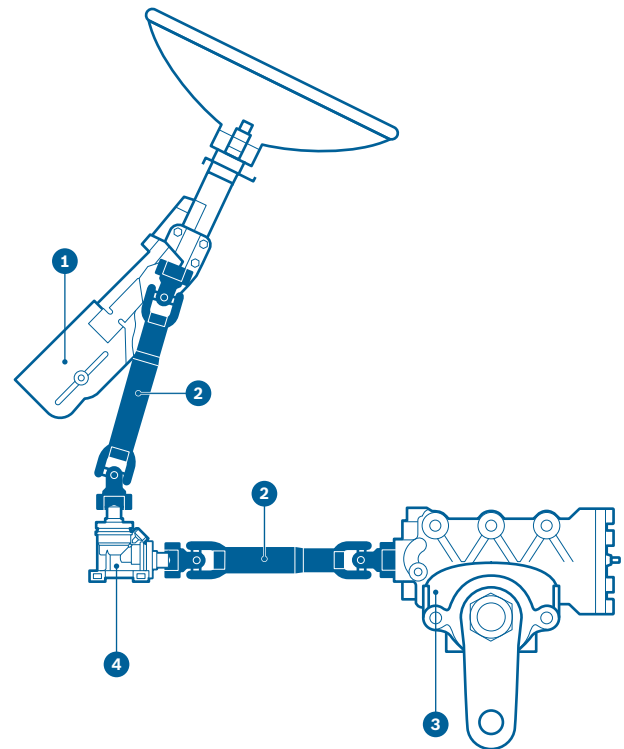

Steering systems

Bevel box



BOSCH

Invented for life

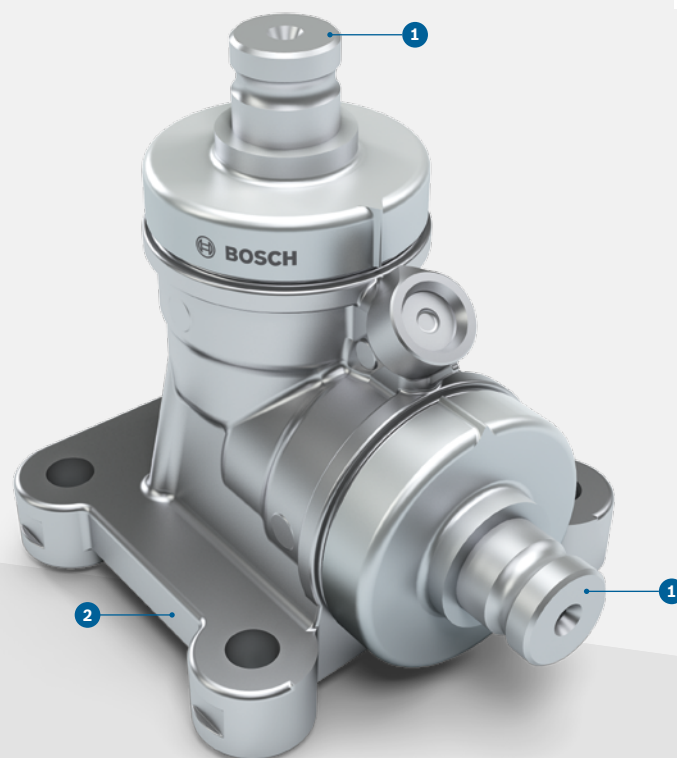

PRODUCT BENEFITS

- ▶ Low weight
- ▶ Low wear
- ▶ Maintenance-free due to continuous lubrication

- 1 Drive shaft/drawn shaft
- 2 Light-metal housing



2,000,000 km lifetime

The Bosch bevel box offers a high level of reliability thanks to its robust design – tried and tested many times in all markets and for all applications.

TASK

Bevel boxes for commercial vehicles are used, when direct linkage by means of a ball-track telescopic shaft is not possible due to the arrangement of the steering gears in relation to the steering column. Bosch bevel boxes are available in several designs, which are adapted to the familiar installation positions. They can be flanged directly onto the RB-Servocom® or installed separately in the vehicle. The usual standard is a shaft angle of 90°.

FUNCTION

The bevel box consists essentially of a drive or drive shaft including the bevel gearing, the appropriate bearing and the housing. The drives or drive shafts have roller bearings. Generally both shafts carry a straight-toothed bevel gears with the same number of teeth, and these give a 1:1 transmission. The oil filling provides continuous lubrication, and this has a particularly beneficial effect on the noise level and wear performance. The robust light-metal housing contributes to weight reduction. A wide range of special designs up to 120° shaft angle is also available to meet the requirements of customers.

TECHNICAL CHARACTERISTICS

Transmission	1:1
Operating temperature	-40 °C to +80 °C
Static breaking torque	> 500 Nm
Weight	2.2 kg

high steering accuracy

due to precision gearing and low friction torque

- 1 Adjustable steering column
- 2 Steering shaft
- 3 RB-Servocom® steering gear
- 4 Bevel box

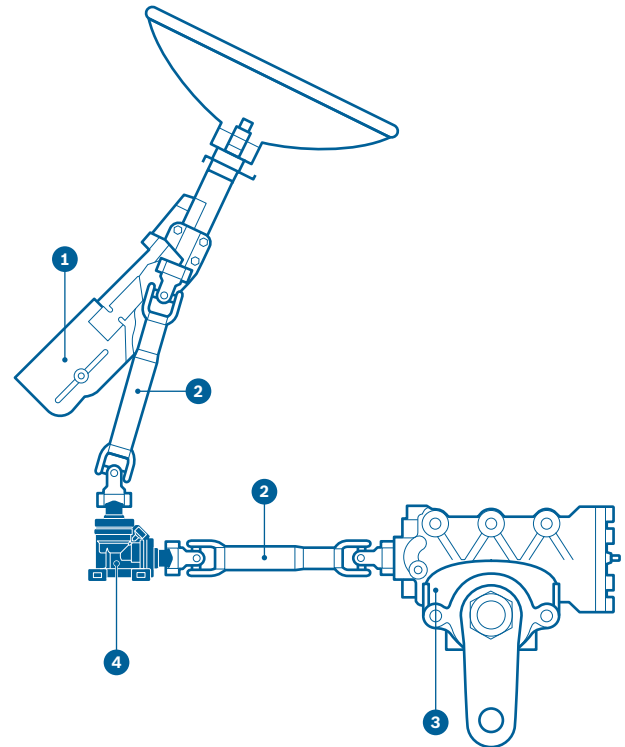

Bosch – your partner for steering systems on commercial vehicles



20 LOCATIONS ON FOUR CONTINENTS

Global presence Robert Bosch Automotive Steering has a total of 20 locations in eight countries. This means that we have a presence worldwide in all the core automobile markets – in Europe and Asia, as well as in North and South America. Worldwide there are 14,500 staff employed in the development and production of steering systems, among them 1,500 specialists engaged in creating the perfect steering feel.



SYSTEM SUPPLIER WITH COMPREHENSIVE EXPERTISE

System and network competence We offer our customers not just components, but also complete systems that are perfectly matched, and which incorporate our expert knowledge in all areas of steering systems for commercial vehicles. As part of the Mobility Solutions business sector of Bosch, we are able to network our solutions with the entire spectrum of vehicle systems, such as control units and sensors, to the benefit of our customers.



HOLD THE LANE OVER THE LONG HAUL AND PULL TOGETHER AS ONE

Long-term partnership As the world's leading manufacturer of steering systems, power steering pumps and components for commercial vehicles, Robert Bosch Automotive Steering is an experienced and capable partner to the automotive industry. Our customers appreciate us, because we are trustworthy, reliable and experts in our field, and because we can support them over the entire life cycle of the vehicle – from the joint development project to the worldwide supply of spare parts.



PERFECT STEERING FEEL IS OUR CORE EXPERTISE

Comprehensive portfolio Whether it is innovative steering systems for commercial vehicles, modern easy-entry steering columns or particularly economical power steering pumps, Robert Bosch Automotive Steering offers a comprehensive range of wheel-to-wheel solutions and products, which meet all the market requirements for many classes of vehicles. Our core expertise in steering systems is based on decades of experience and proficiency as the world's market leader in steering systems for commercial vehicles.



RELIABLE AND ROBUST ON THE HIGHWAY OR OFF-ROAD

Ensuring quality and reliability Manufacturers throughout the world trust the proven quality of our steering systems, components and services. Our products are in daily use on endless highways, in urban rush hours and on tracks far removed from asphalted roads, and they have proved their quality and robustness millions of times over.



DISTINGUISHED FOR TECHNICAL PROGRESS

Innovation driver and technology leader Robert Bosch Automotive Steering is the market leader internationally in the sector of steering systems for commercial vehicles. Our products define technical progress in their action and innovation. The awards for our products also stand for this distinction, including the Innovation Award of the German Business Association, as well as the high level of satisfaction of our customers.